

Grundriss - Ground plan

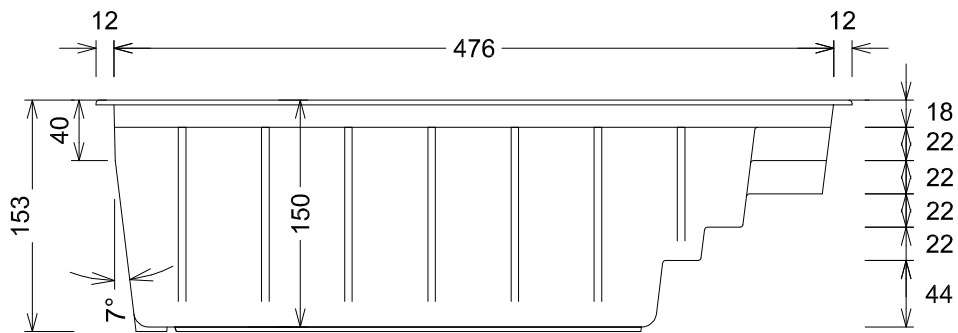

Seitenansicht - Side view

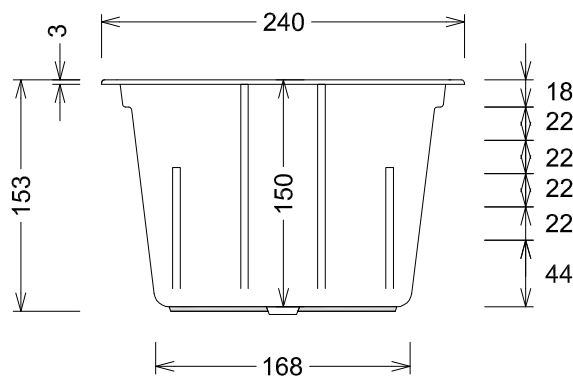

Ansicht Skimmerseite - View skimmer side

Bedingt durch den Herstellungsprozess können die Maße des Beckenkörpers variieren. Deshalb sind die angegebenen Maße nur annähernd und unverbindlich. Toleranzen gemäß DIN EN 16582-1 und DIN EN 16582-2

Due to the manufacturing process, the dimensions of the pool body may vary. Therefore, the given dimensions are approximate and not binding. Tolerances according to DIN EN 16582-1 and DIN EN 16582-2

